

本图所叙的资料是机密的, 版权为常熟富莱斯特热流系统制造有限公司所有. 未经同意, 严禁复制.

修订记录				
版本	描述	日期	修订	批准
1	First release	2019-06-05	J.Z.	D.W.
2	Add -01	2019-08-29	J.Z.	D.W.

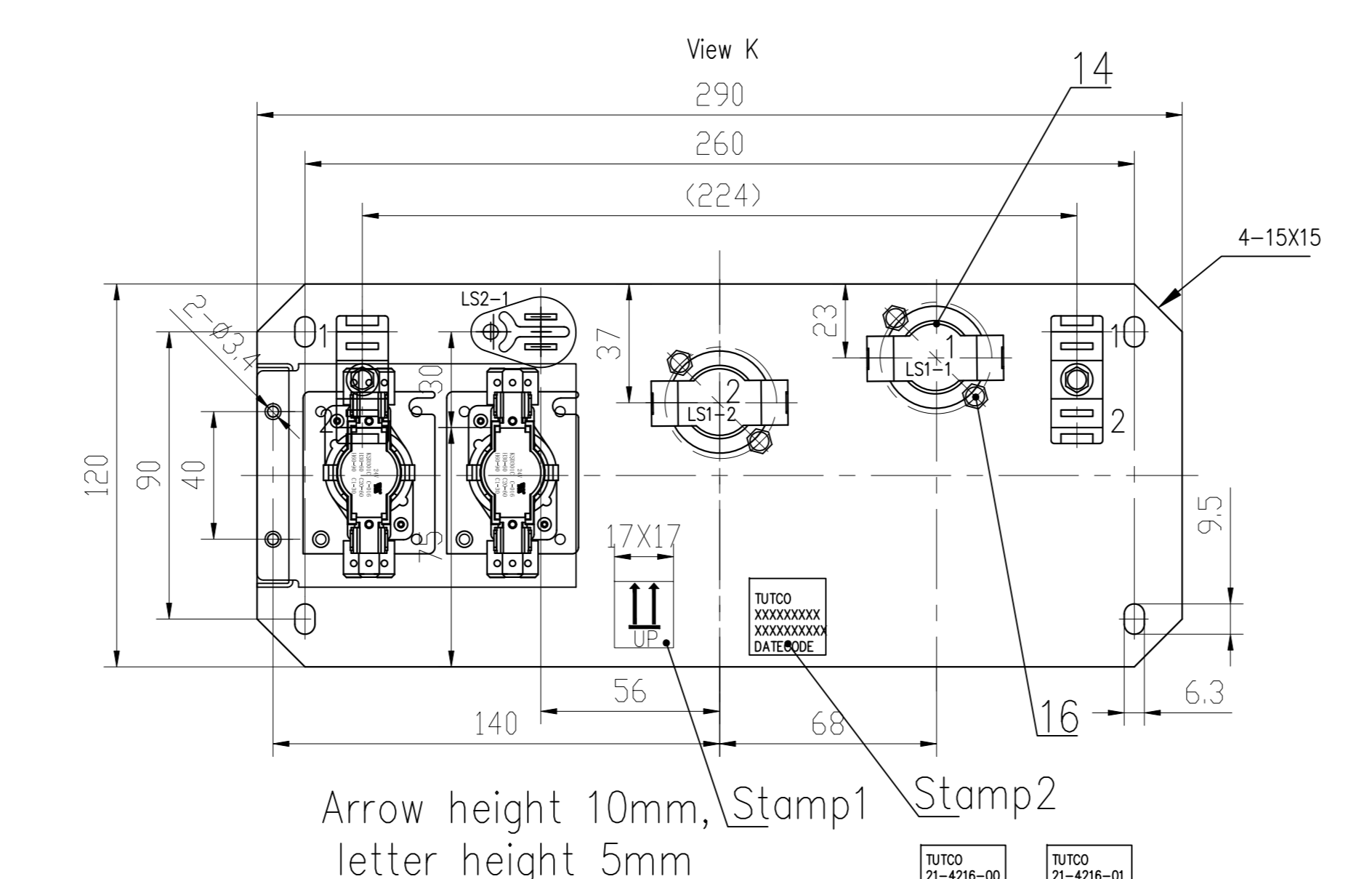
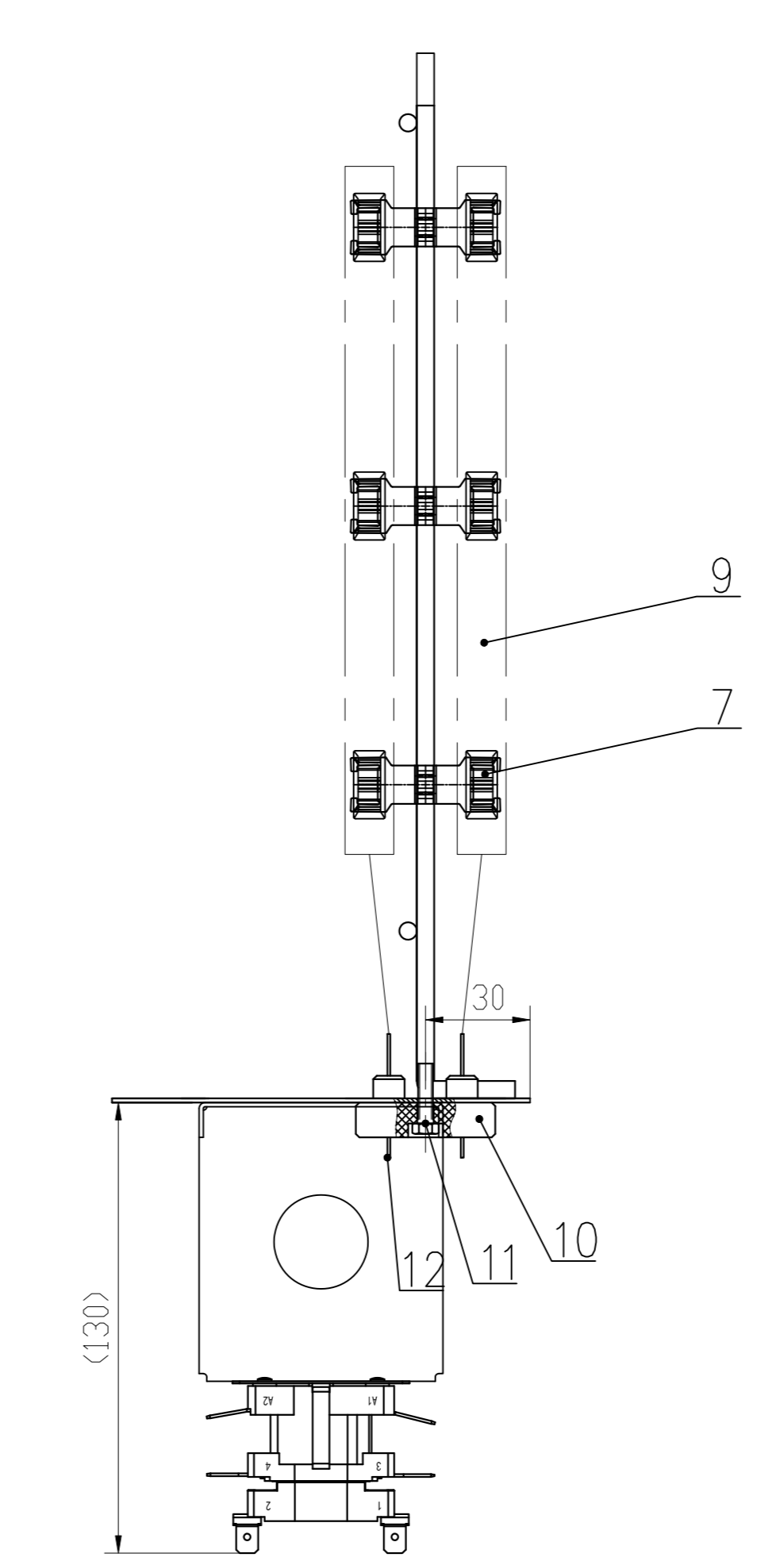
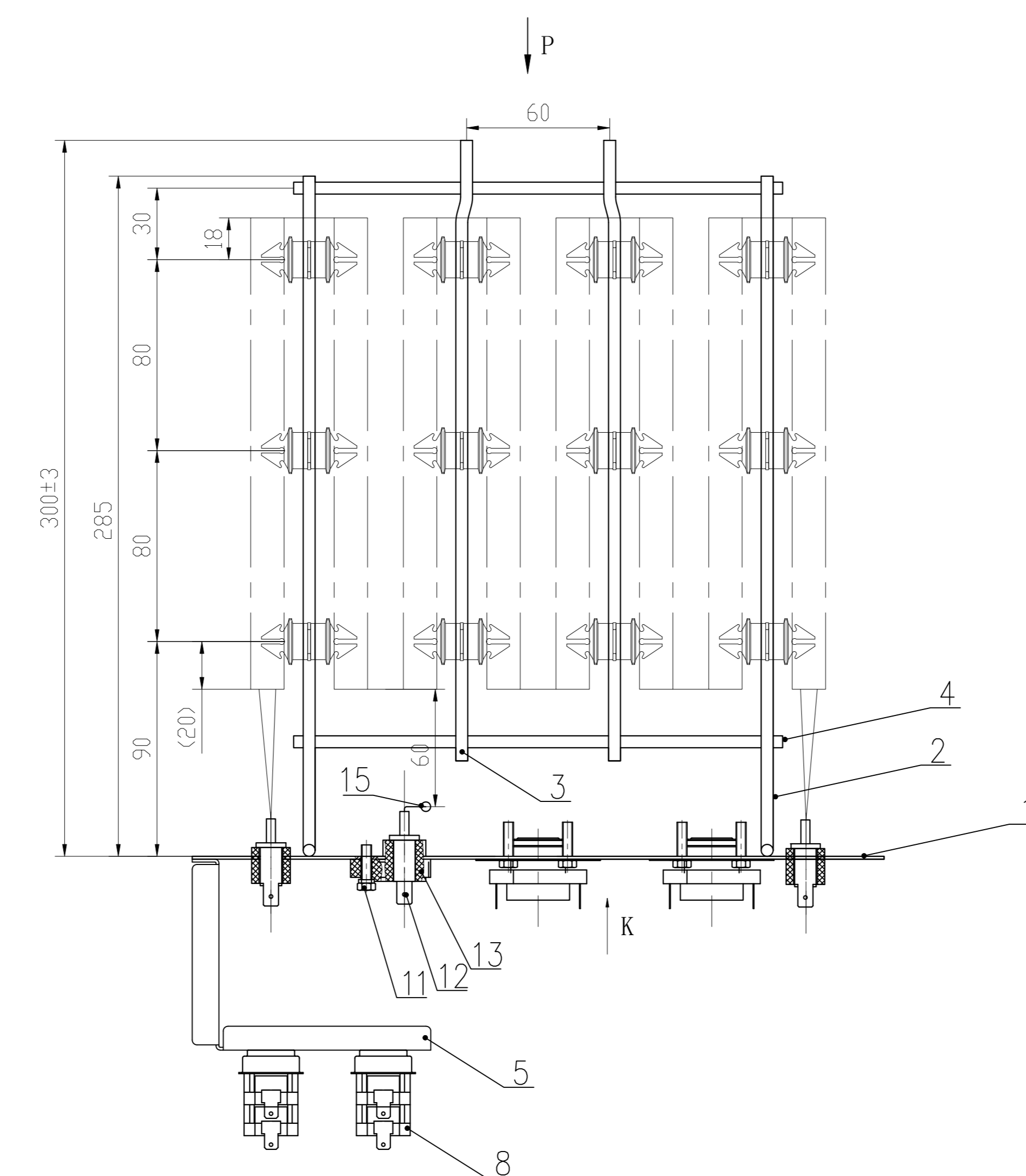
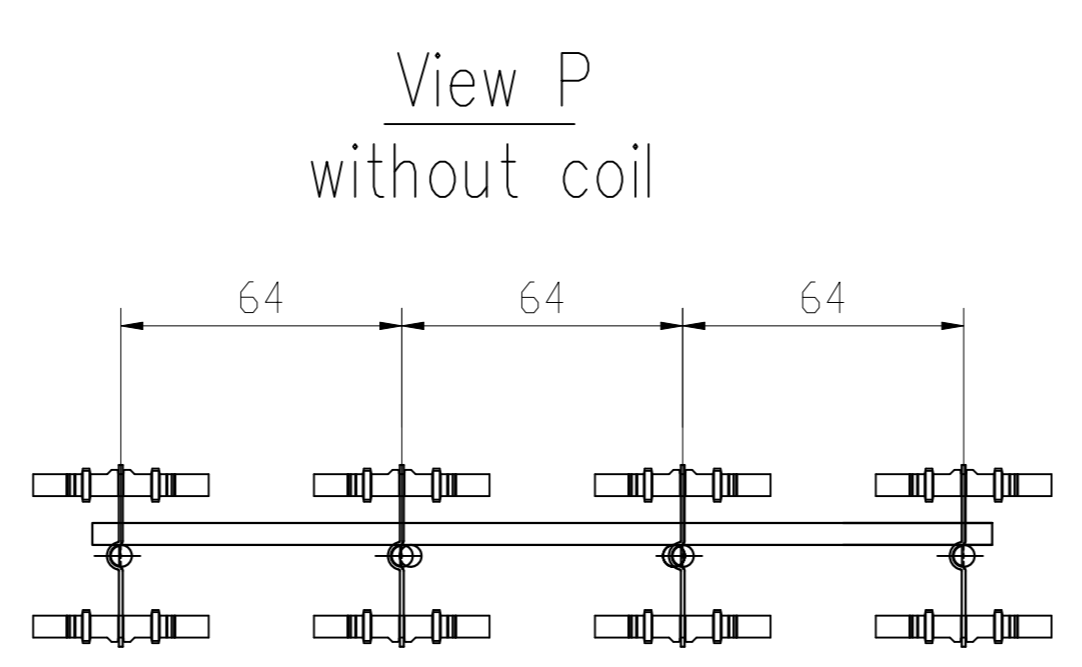
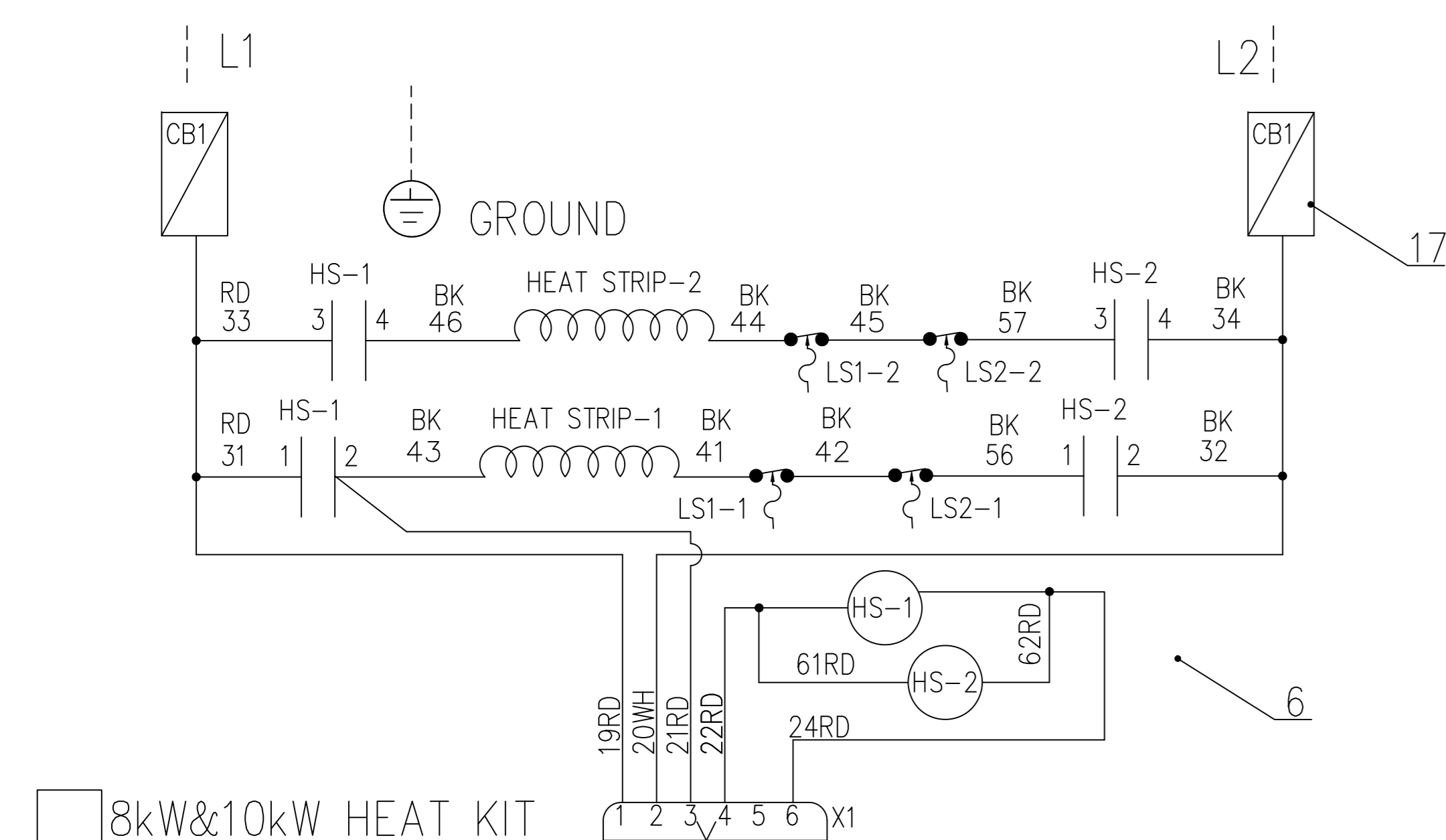

**NOTE:**

- Rated Power: see table, power rangen is  $\pm 5\%$ ;
- Hi-pot test: AC1800V/1S,  $\leq 5\text{mA}$ , without breakdown and flashover;
- Insulation resistance: 500VDC,  $\geq 100\text{M}\Omega$ ;
- Leakage current  $\leq 5\text{mA}$  under working voltage;
- The product does not allow obvious burrs and sharp edges, and must remove all oil stains;
- All parts and components should be fixed and secure, all welding is spot welding, spot welding should be in place, no looseness, no swaying left and right, There are no crack corrosion marks on all parts; ceramic parts are not allowed to have chamfers and cracks, and ceramics are not allowed to loosen on the iron clips;
- The surface of the product is not allowed to have serious scratches and scratches; the plating layer should be even and firm, and there should be no air bubbles, peeling or partial accumulation;
- The coil pitch should be uniform; the electrical clearance and creepage distance between the live parts and the metal bracket is greater than 6.4 mm;
- Ceramic parts are not allowed to have chamfers and cracks, and ceramics are not allowed to loosen significantly on the iron clips;
- Electric heaters should meet the requirements of UL 499.
- Materials required by the ROHS Directive shall comply with relevant standards.
- All parts must meet the neutral salt spray test 96H, after test there is no red rust that cannot be wiped (except for spot welds).

No.	P/N	Name	QTY	Description	Remark
17	SEE TABLE	Circuit breaker	1	Schneider	
16	C07-0108-00	Screw	8	STP6#-32*5	
15	08-2928-144	FUSE	2	TOD G8 144C	
14	08-3993-00	Auto reset Thermostat	2	TOD 60TX01 L140-35F	
13	05-0338-00	Ceramic Insulation	2	Ceramic	
12	08-3110-00	250 Male terminal	8	SUS304	
11	C07-0113-00	Screw	6	#8-18 X .250 ZINC	
10	05-0337-00	Ceramic Insulation	2	Ceramic	
9	SEE TABLE	Coil	2	KANTHAL "NXT"	
8	08-3994-01	Relay	2	KSD301C C-016	
7	C48-0322-04	Half Clip & Flat	12	Ceramic	
6	46-7622-00	Wire harness	1	UL1015	Refer to circuit diagram
5	48-4238-00	Relay plate	1	G90 Galvanized sheet	
4	48-4237-01	Support Bar	2	$\phi 5$ SUS304	
3	48-4232-00	Frame Bar 2	2	$\phi 5$ SUS304	
2	48-4231-00	Frame Bar 1	2	$\phi 5$ SUS304	
1	48-4230-00	Terminal Plate	1	G90 Galvanized sheet	

21-4216-01	32102208	10.132 $\pm 5\%$ $\Omega$ 5000W 240V Coil OD $\phi 14.1$ (Ref.) #15.5 GA."NXT" 04-9459-01	10KW 240V	08-2862-00 Schneider QOU260
21-4216-00	32102202	12.665 $\pm 5\%$ $\Omega$ 4000W 240V Coil OD $\phi 13.6$ (Ref.) #17 GA."NXT" 04-9459-00	8KW 240V	08-2863-00 Schneider QOU245
TUTCO P/N	CUST. P/N	Item 9 Coil	Description	Item 17

500 Gould Drive/Cookeville, TN 38506

材料:

表面处理:

标题: **Heater Assembly**

未注公差

GB/T1804-C

视图方向

制图:

审核:

批准:

日期:

日期:

日期:

图纸编号 21-4216-00

比例 1:1

图纸尺寸 A4

请勿实测图面尺寸

版本号: 2

单位 mm

第 1 页 共 1 页

品质关键点