

TOSOT COMFORT

Model: GMV-ND09G/B4B-T(U)

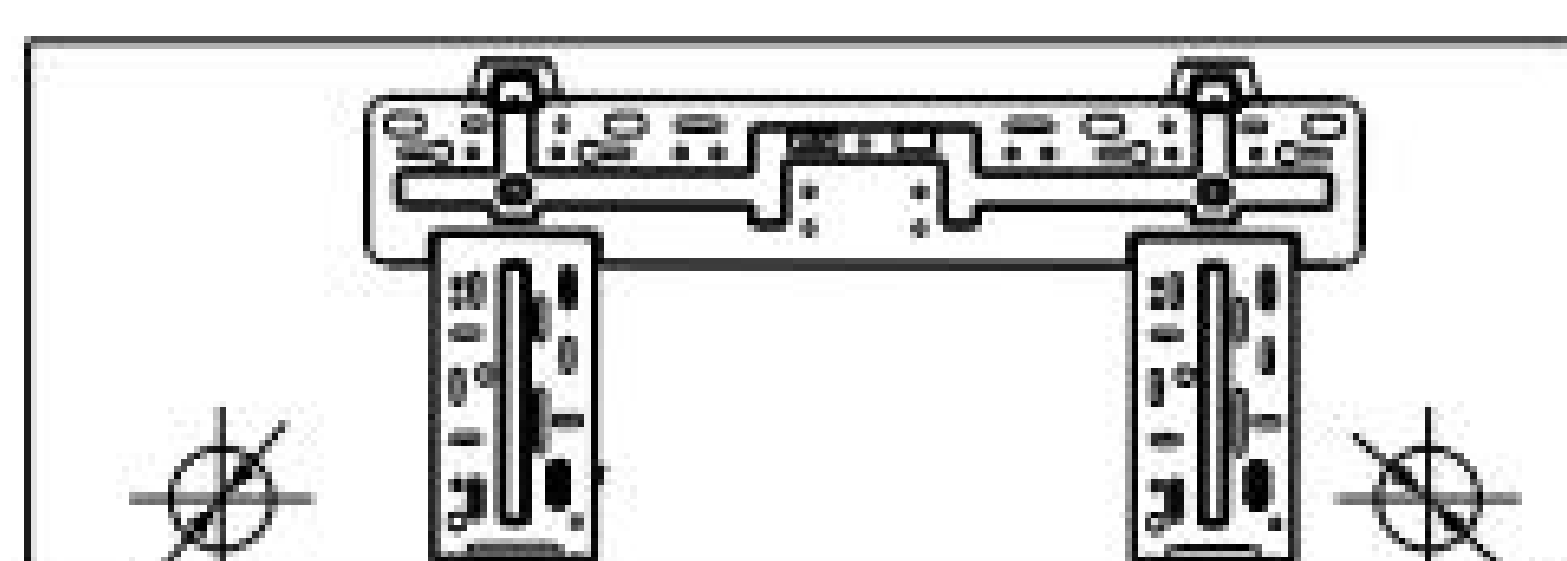
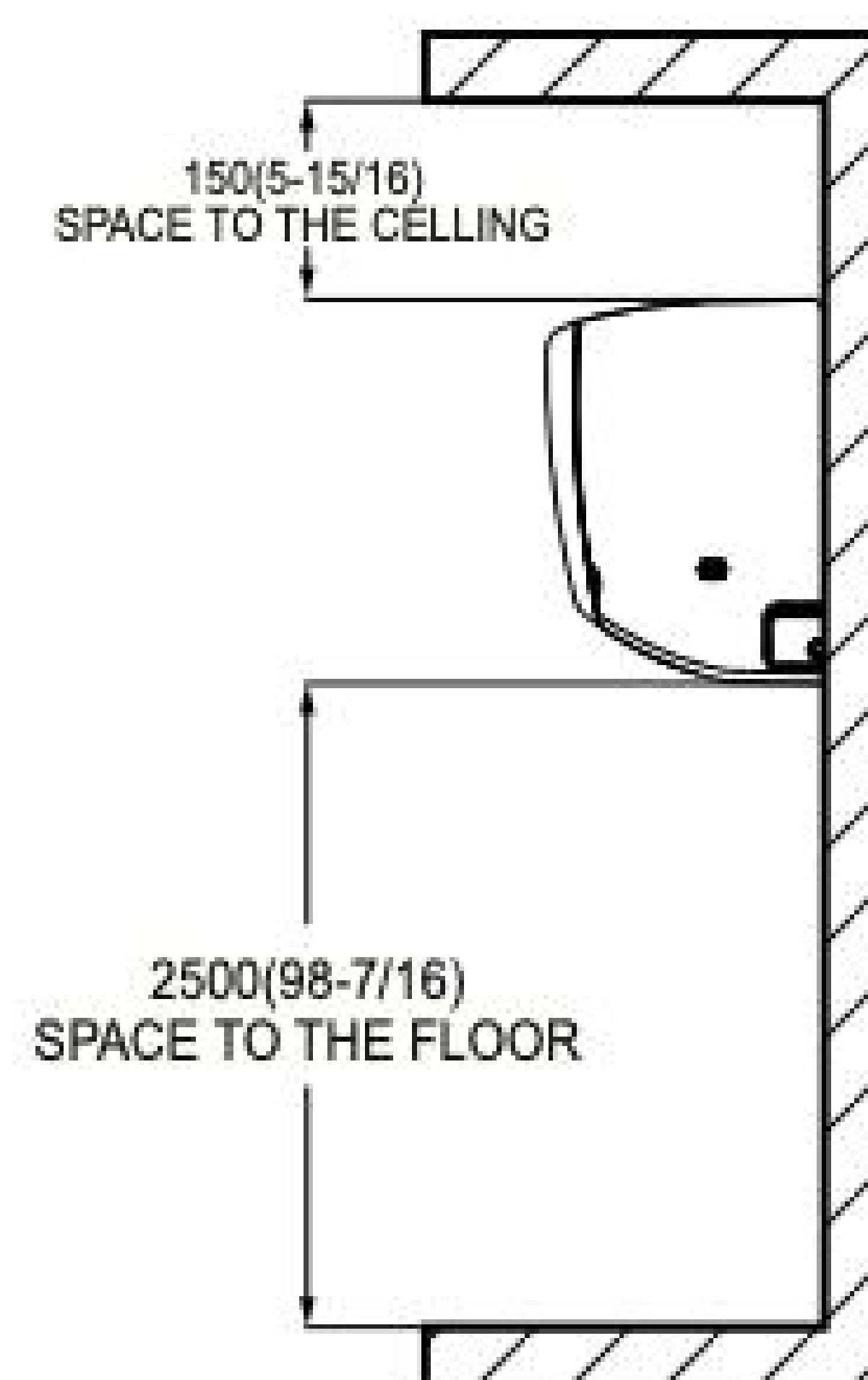
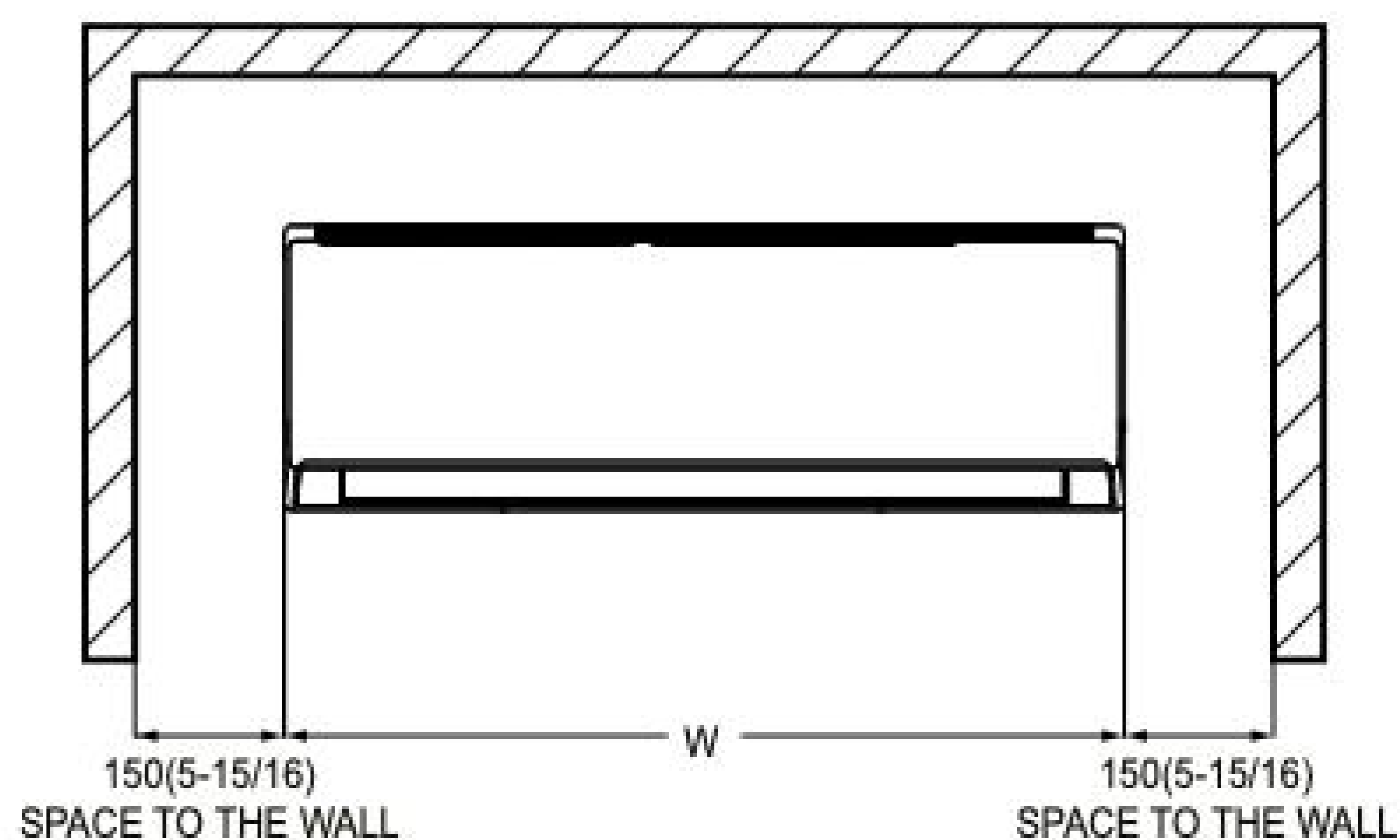
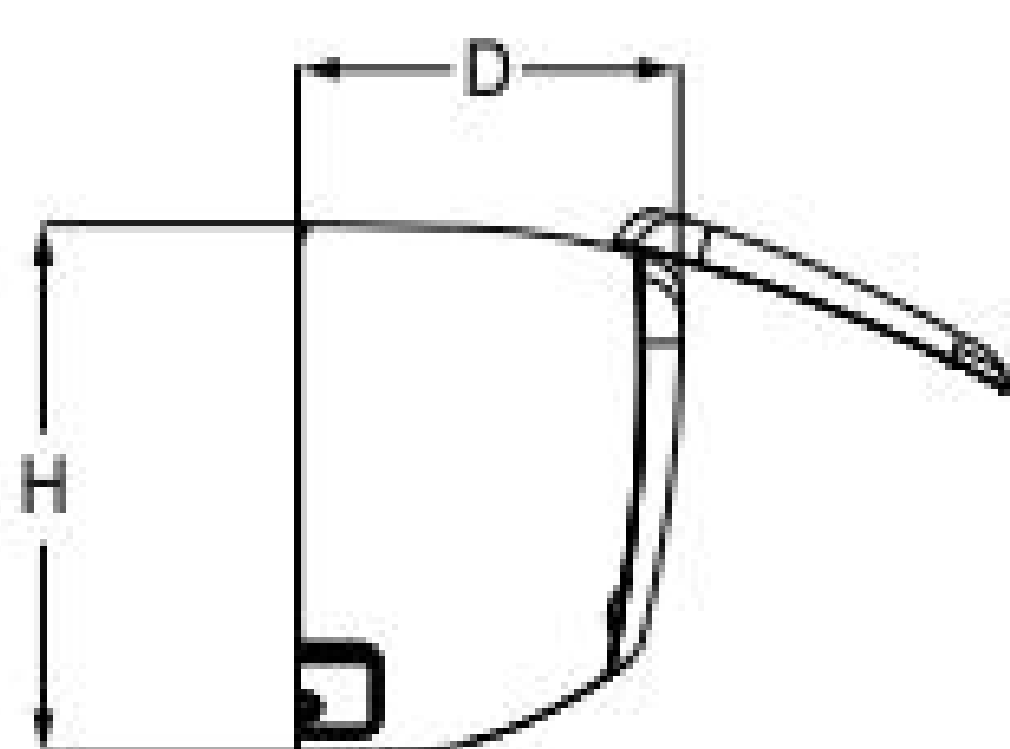
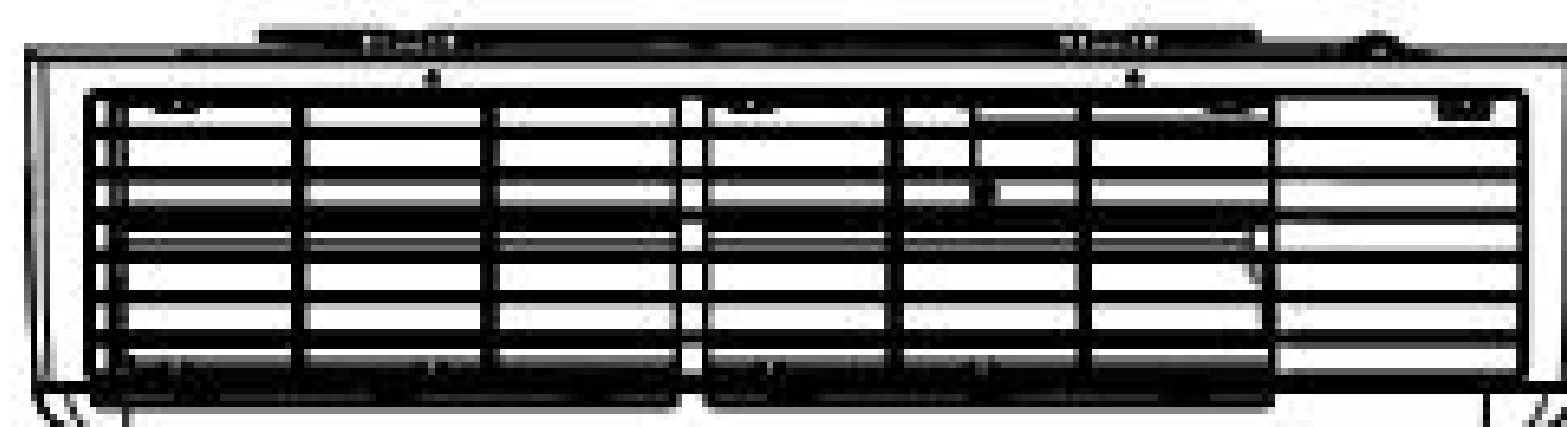

Left $\Phi 55(2-3/16)$ or $\Phi 70(2-3/4)$
(Rear piping hole)

Right $\Phi 55(2-3/16)$ or $\Phi 70(2-3/4)$
(Rear piping hole)

Specification	Unit	Parameter
Performance		GMV-ND09G/B4B-T(U)
Rated Cooling Capacity	kBtu/h	9.5
Rated Heating Capacity	kBtu./h	10.5
Sound Pressure Level (H/M/L)	dB(A)	35/33/30
Fan		
Type x Quantity		Cross-flow x 1
Air Flow Volume (H/M/L)	CFM	294/259/177
Fan Motor Running Current	A	0.1
Fan Motor Power Input	W	20
Electrical Data		
Power Supply	Voltage, Phase, Hertz	208/230, 1, 60
Minimum Circuit Amps (MCA)	A	1
Maximum Overcurrent Protection (MOP)	A	15
Refrigerant Piping		
Connection Pipe	Gas (inch)	3/8
	Liquid (inch)	1/4
Connection Method	Flare Connection	
Refrigerant	R410A	
Dimension/Weight		
Dimensions (HxWxD)	inch	33-1/4 x 8-1/4 x 11-3/8
Net Weight	lbs	23.5
Other		
Safety Certification		ETL

10 years warranty on parts and compressors
www.tosotcomfort.com