

## DIMENSIONS

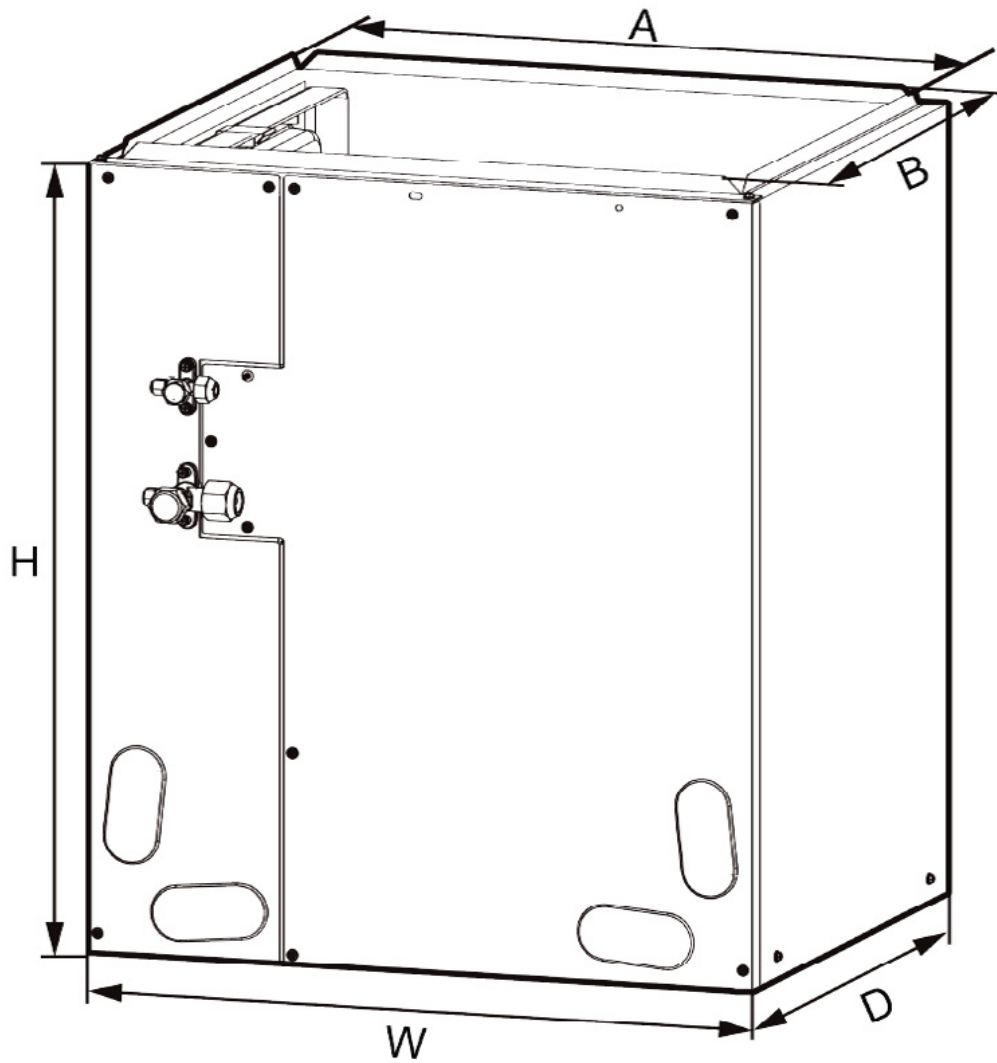

### DIMENSIONS

A 22-7/8

B 19-3/8

H 28-1/2

W 24-1/2

D 21-1/4

## SPECIFICATIONS, FEATURES & FUNCTION SUMMARY

SPECIFICATIONS		TCAT60F/NaA		SYSTEM FEATURES	
System Type		HEAT PUMP			
SYSTEM PERFORMANCE					
Cooling	Min - Max	Btu/h	35000 - 54000	Compressor	Inverter
	Capacity @95°F	Btu/h	50500	Ultra Low Frequency Torque Control	Yes
Heating	Min - Max	Btu/h	35000 - 60000	Power Factor Correction	Yes
	Capacity @5°F	Btu/h	37200	Compressor Type	Rotary
	Capacity @17°F	Btu/h	35200	Refrigerant Type	R410A
	Capacity @47°F	W	53000	Outdoor Electronic Expansion Valve (EEV)	Yes
SEER2			15.2	Indoor TXV Control	Yes
EER2			9.5	Basepan With Electric Heater	Yes
HSPF2			8.5	Compressor With Electric Heater	Yes
COP @5°F			1.8	Fin Coating (Outdoor - Golden & Indoor - Blue)	Acrylic Resin
COP @47°F			3.5	Intelligent Defrosting	Yes
Cooling Temperature Range	°F		5 - 129	Intelligent Preheating	Yes
Heating Temperature Range	°F		-22 - 75	Low Voltage Startup	Yes
Refrigerant Type			R410A	Memory/Power Failure Recovery	Yes
INDOOR UNIT		TCAT60F/NaA			
Dehumidification	pt/hr		12.13	Self Diagnosis	Yes
Condensate Drain Size (OD)	in		3 / 4	Low Ambient Cooling	Yes
External Dimensions (W x H x D)	in		24-1/2 x 28-1/2 x 21-1/4	24VAC Thermostat Compatible	Yes
Package Dimension (W x H x D)	in		28-1/8 x 31-5/16 x 27-1/8		
Refrigerant Charge - R410A	oz		8.8		
Net Weight	lbs		94.8		
Gross Weight	lbs		110.2		
OUTDOOR UNIT		TU60-24WADU			
Power Supply	VAC		208-230V / 1Ph / 60 Hz		
Sound Pressure Level	dB(A)		58		
Control Voltage	VAC		24		
Rated Current Cooling	A		30		
Rated Current Heating	A		31		
MCA	A		35		
MOCP	A		45		
Recommended Breaker Size	A		40		
External Dimensions (W x H x D)	in		39-3/8 x 53-5/8 x 14-1/2		
Package Dimension (W x H x D)	in		45-7/16 x 59-1/4 x 19-7/16		
Net Weight	lbs		308		
Gross Weight	lbs		337		
Refrigerant Charge - R410A	oz		220.5		
Additional Charge	oz/ft		0.32		
REFRIGERANT PIPING					
Line Set Size (Liquid - Gas) - Flared Connections	in		3/8 - 3/4		
Pre-Charge Length	ft		31		
Additional Charge	oz/ft		0.32		
Pipe Length (Min - Max)	ft		10 - 164		
Max. Pipe Elevation	ft		50		